

**HAFCO WOODMASTER**

# AIR FILTRATION SYSTEM OPERATION MANUAL



**Model**  
**AF-400**  
ORDER CODE W325

*Edition No* : AF-401

*Date of Issue* : 12/2018

[www.machineryhouse.com.au](http://www.machineryhouse.com.au)



# OPERATION MANUAL

## MACHINE DETAILS

<b>MACHINE</b>	AIR FILTRATION SYSTEM
<b>MODEL NO.</b>	AF-400
<b>SERIAL NO.</b>	
<b>DATE OF MANF.</b>	

DISTRIBUTED BY



[www.machineryhouse.com.au](http://www.machineryhouse.com.au)

[www.machineryhouse.co.nz](http://www.machineryhouse.co.nz)

**NOTE:**

This manual is only for your reference. Owing to the continuous improvement of the HAFCO machines, changes may be made at any time without obligation or notice. Please ensure the local voltage is the same as listed on the specification plate before operating this electric machine.



**NOTE:**

In order to see the type and model of the machine, please see the specification plate. Usually found on the back of the machine. See example (Fig.1)

**HAFCO**  
PRODUCT SPECIFICATION

MODEL:

CAPACITY:

SER. NO:

MFG DATE:

WEIGHT:

VOLTS:

MOTOR Kw:

[www.machineryhouse.com.au](http://www.machineryhouse.com.au)  
Made in China

FIG.1



# OPERATION MANUAL

## CONTENTS:

1. GENERAL MACHINE INFORMATION	
1.1 Specifications .....	4
1.2 Accessories.....	4
1.3 Identification.....	5
2. IMPORTANT INFORMATION	
2.1 General Safety Requirements .....	6
2.2 Additional Safety For AF-400.....	8
2.3 Electrical Requirements.....	8
3. SETUP	
3.1 Placement.....	9
3.2 Unpacking.....	9
3.3 Mounting the Air Filter.....	9
4. OPERATION	
4.1. Controls and Features.....	10
4.2 Cleaning The Filters.....	11
5. MAINTENANCE	
5.1 Troubleshooting.....	12
5.2 Fuse Replacement.....	13
5.3 Remote Battery Change.....	13
SPARE PARTS.....	14
RISK ASSESSMENT SHEETS.....	17

**1.1 SPECIFICATIONS**

ORDER CODE	W325
<b>MODEL</b>	<b>AF-400</b>
OUTER FILTER	5 MICRONS
INNER FILTER	1 MICRON
OVERALL DIMENSIONS (LXWXH/IN)	515 X 432 X 258MM
SOUND RATING @ 3FT (HIGH SPEED)	69DB
SOUND RATING @ 3FT (MEDIUM SPEED)	67DB
SOUND RATING @ 3FT (LOW SPEED)	62DB
AIR FLOW HIGH SPEED (C.F.M)	409
AIR FLOW MEDIUM SPEED (C.F.M)	362
AIR FLOW LOW SPEED (C.F.M)	260
MOTOR (WATTS/HP)	94/.125
POWER	240V 1PH 50HZ
TIMER SETTINGS (HOURS)	1.2 AND 4
NET WEIGHT (KGS)	14.0

**1.2 ACCESSORIES**



MOUNTING HOOKS AND CHAIN



REMOTE CONTROL

**1.3 IDENTIFICATION**

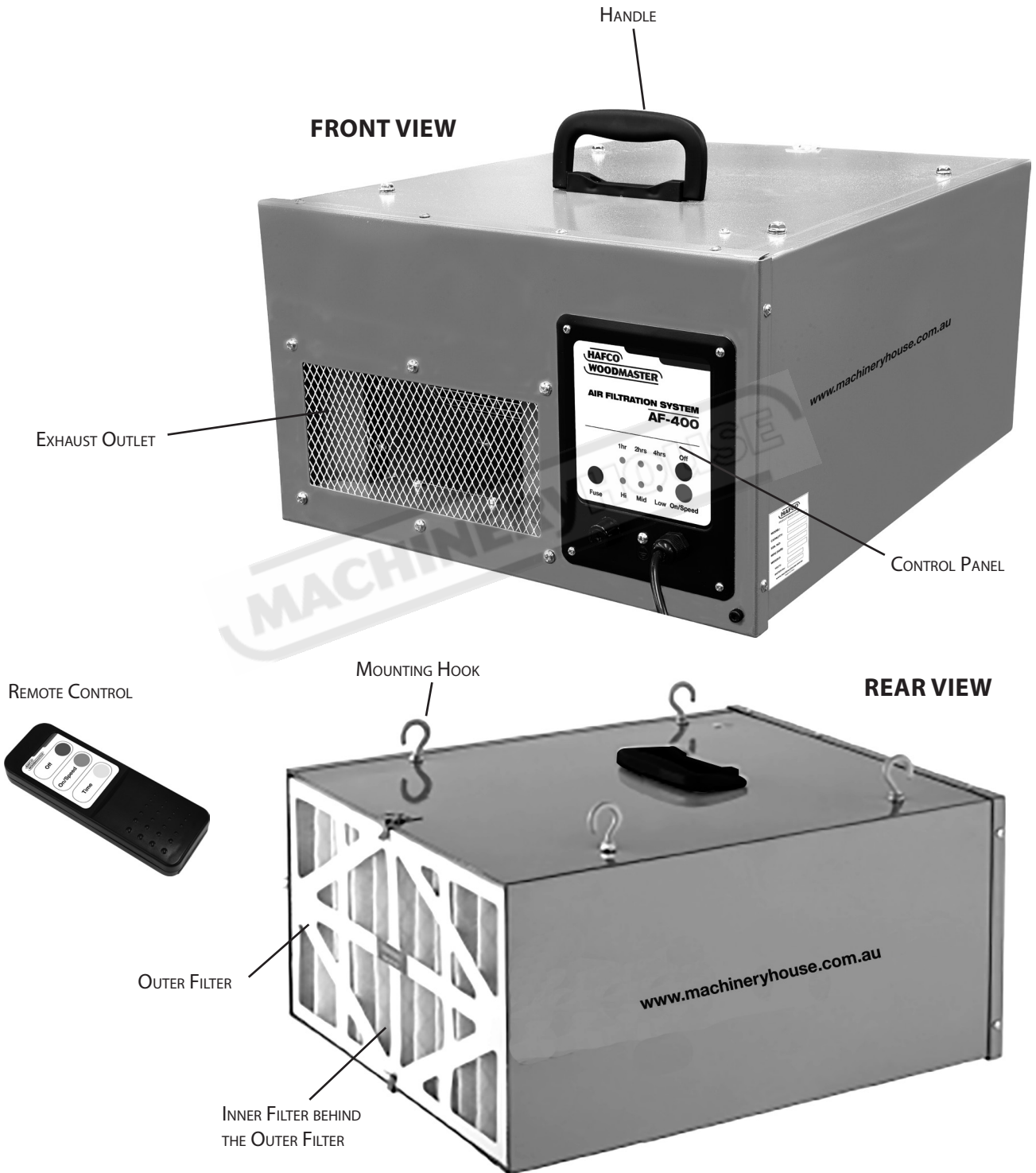

## 2. IMPORTANT INFORMATION

### 2.1 GENERAL SAFETY REQUIREMENTS

DO NOT use this machine unless you have read this manual or have been instructed in the use of this machine in its safe use and operation



# WARNING

This manual provides safety instructions on the proper setup, operation, maintenance, and service of this machine. Save this manual, refer to it often, and use it to instruct other operators. Failure to read, understand and follow the instructions in this manual may result in fire or serious personal injury—including amputation, electrocution, or death.

The owner of this machine is solely responsible for its safe use. This responsibility includes, but is not limited to proper installation in a safe environment, personnel training and authorization to use, proper inspection and maintenance, manual availability and comprehension, of the application of the safety devices, integrity, and the use of personal protective equipment.

The manufacturer will not be held liable for injury or property damage from negligence, improper training, machine modifications or misuse.

Exposure to the dust created by power sanding, sawing, grinding, drilling and other construction activities may cause serious and permanent respiratory or other injury, including silicosis (a serious lung disease), cancer, and death. Avoid breathing the dust, and avoid prolonged contact with dust. Some examples of these chemicals are:



- Lead from lead-based paints.
- Crystalline silica from bricks, cement and other masonry products.
- Arsenic and chromium from chemically-treated timber.

Always operate tool in well ventilated area and provide for proper dust removal. Use a dust collection system along with an air filtration system whenever possible. Always use properly fitting approved respiratory protection appropriate for the dust exposure, and wash exposed areas with soap and water.



Safety glasses must be worn at all times in work areas. Earmuffs should be worn if the work area is noisy.



Sturdy footwear must be worn at all times in work areas.



Gloves should NOT be worn when operating this machine



Long and loose hair must be contained with a net or under a hat

## 2.1 SAFETY REQUIREMENTS Cont.

**DISCONNECT POWER FIRST.** If using power, always disconnect the machine from power supply before servicing/adjusting the machine. This prevents any risk of injury from unintended startup or contact with live wires.

**WEARING PROPER APPAREL** Do not wear clothing, apparel or jewelry that can become entangled in moving parts. Always tie back or cover long hair. Wear non-slip footwear to avoid accidental slips, which could cause loss of operating control.

**HEARING PROTECTION.** Always wear hearing protection when operating or observing loud machinery. Extended exposure to this noise without hearing protection can cause permanent hearing loss.

**REMOVE ADJUSTING TOOLS.** Tools left on machinery can become dangerous projectiles upon startup. Never leave hex keys, wrenches, or any other tools on machine. Always verify removal before starting!

**USE CORRECT TOOL FOR THE JOB.** Only use this tool for its intended purpose. Do not force the machine or its attachments to do a job for which they were not designed. Never make unapproved modifications. Modifying the machine or using it differently than intended may result in malfunction or mechanical failure that can lead to personal injury or death!

**AWKWARD POSITIONS.** Keep proper footing and balance at all times when operating machine. Do not overreach! Avoid awkward hand positions that make operating control difficult. This could increase the risk of accidental injury

**GUARDS & COVERS.** Guards and covers reduce accidental contact with moving parts or flying debris. Make sure they are properly installed, undamaged, and working correctly.

**TRAINED OPERATORS ONLY.** Only allow trained or supervised people to use this machine. When the machine is not being used, disconnect the power, to the machine to prevent unauthorized use—especially around children. Make the workshop safe.

**FORCING MACHINERY.** Do not force the machine. It will do the job safer and better at the rate for which it was designed.

**NEVER STAND ON MACHINE.** Serious injury may occur if the machine is tipped or if the cutting tool is unintentionally contacted

**STABLE MACHINE.** Unexpected movement during operation greatly increases risk of injury or loss of control. Before starting, verify machine is stable and if using a mobile base it is locked in position.

**UNATTENDED OPERATION.** To reduce the risk of accidental injury, turn the machine OFF and ensure all moving parts have completely stopped before walking away. Never leave the machine running while unattended.

**MAINTAIN WITH CARE.** Follow all maintenance instructions and lubrication schedules to keep the machine in good working condition. A machine that is improperly maintained could malfunction, leading to serious personal injury or death.

**CHECK DAMAGED PARTS.** Regularly inspect the machine for any condition that may affect the safe operation. Immediately repair or replace damaged or parts that are incorrectly fitted before operating.

**CHILDREN & BYSTANDERS.** Keep children and bystanders at a safe distance from the work area. Stop using machine if they become a distraction.

## 2.2 ADDITIONAL SAFETY REQUIREMENTS FOR AF-400

- Do not use the HAFCO/WOODMASTER Air Filtration System for anything other than wood dust. Materials such as liquids, metal shavings, metal dust, glass, plastic or rock particles could cause damage if they were to come in contact with any part of the machine.
- Never place hands near the inlet grill of the machine.
- Always make sure the machine is off and unplugged when working near the inlet.
- To reduce the risk of injury unplug the air filter from the power source and ensure the fan is stationary before servicing or changing filters.
- If ceiling mounted, the bottom of air filter must be at least 2.13M above the floor.
- If ceiling mounted, mounts must be anchored to building structure which will support a minimum of 45 kg. Never mount to surfaces such as dry wall or false ceiling grids, etc.
- To reduce the risk of electrical shock, do not expose air filter to water or rain.
- Never duct a machine directly into the air filter.
- To avoid a potentially dangerous situation, do not use this equipment to filter volatile fumes or smoke. This air filter is designed and intended for the filtration of air borne wood dust only. It is neither designed nor intended for any other purpose whatsoever.
- Failure to comply may result in serious injury and could cause property damage.

## 2.3 ELECTRICAL REQUIREMENTS.

- Should there be a malfunction or breakdown, earthing provides a path of least resistance for electric current to reduce the risk of electric shock. This machine is equipped with an electric lead having an earthing conductor and an earthing plug. The plug must be plugged into a matching outlet that is properly installed and earthed in accordance with all local regulations. (Fig. 2)
- Do not modify the plug provided. If it will not fit the outlet, have the proper outlet installed by a qualified electrician.
- The improper connection of the earth pin on the plug can result in a risk of electric shock. The plug pin, has insulation having an outer surface that is green, with or without yellow stripes. The repair or replacement of the electric lead or plug must be carried out by a qualified electrician.
- The power supply required is a 10 amp 240 Volt single phase 50Hz. The full load current is 1 amp.

### **⚠ WARNING**

Equipment must be earthed while it is use to protect the operator from electrical shock. The mains connection and any extension leads used must comply with the local regulations. The mains power supply must comply with the information on the machine's specification label. Any electrical work must be done by a qualified electrician



FIG.2



### 3. SETUP

#### 3.1 PLACEMENT

- ❑ The air filter unit does not require much assembly, but consideration should be given to how and where the unit is to be placed. This unit is specifically designed to filter non-metallic dust, when it is generated throughout the work area, and return it as clean air.
- ❑ The unit operates at its optimum when it is hung from the ceiling, located away from corners of the room or near any heating or cooling vents. A minimum ceiling height of 2.3 metres is required. The unit can also operate when placed on a bench or a cabinet. If it is to be used sitting on sawhorses, the air filtration unit needs to be secured in place.

#### 3.2 UNPACKING

This machine was carefully packaged for safe transport. When unpacking, separate all enclosed items from packaging materials and inspect them for shipping damage. If items are damaged, please contact your distributor.

**NOTE:** Save all the packaging materials until you are completely satisfied with the machine and have resolved any issues with the distributor, or the shipping agent.

When unpacking, check to make sure that all parts shown on page 4 are included. If any parts are missing or broken, please contact your distributor.

#### 3.3 MOUNTING THE AIR FILTER

The air filtration unit works best if it is hung from the ceiling.

##### To mount the air Filter from the ceiling;

1. DISCONNECT THE POWER PLUG FROM THE SOCKET
2. Remove all packing from inside of the unit by removing the outer filter and inner filters.
3. Remove the four screws from the top of the cabinet and hang the unit using the four hook bolts (Fig 3, B), and four hex nuts (Fig 3, C) supplied
4. The lock nut needs to be threaded almost all the way up the eyebolt. Screw the eye bolt into the hole and tighten lock nut against the cabinet top. You will need to hold the eyebolt so it does not spin while tightening the lock nut.
5. Drill holes and securely mount the four mounting hooks provided in the ceiling and use the provided sections of chain for mounting your air filtration system.

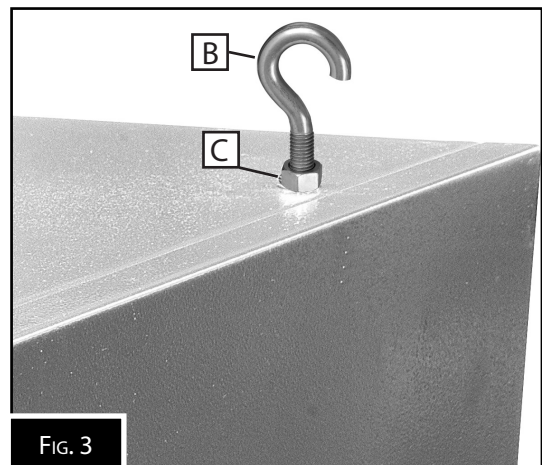

FIG. 3

## 4. OPERATION

### 4.1 CONTROLS & FEATURES

Remote Control:

**TIME button** (Fig. 4) controls the three different timer settings.

**1H** will light up on the back of the unit by pressing the time button once. (Fig.5) The machine will operate for 1 hour then shut off.

**2H** will light up on the back of the unit by pressing the time button twice. (Fig.5) The machine will operate for 2 hours then shut off.

**4H** will light up on the back of the unit by pressing the time button three times. (Fig.5) The machine will operate for 4 hours then shut off.

**ON/SPEED button** (Fig. 4) Turns unit ON and controls the three different fan settings, LO, MID and HI. There is also a on/speed button (Fig. 5) on the backside of this unit which controls the speed and turns the unit ON in LO speed.

**OFF button** (Fig. 4) turns the unit off. There is also a manual OFF button (Fig. 5) on the backside of the AFS unit.

**Fuse** (Fig. 5) will blow in the case of overload. Replace with equivalent 1A fuse.

**⚠ WARNING** Before servicing or changing filters, unplug the air cleaner from the power source and ensure the fan is stationary. Failure to comply may cause serious injury or damage to the machine.



FIG. 4



FIG. 5

## 4.2 CLEANING THE FILTERS

The amount of air filter operation has a direct bearing on when you must clean or replace the filters.

To maintain efficient operation, check the filters approximately every 40 hours of use in light or moderately dusty environments. In very dusty environments, check the filters every eight hours of use. Always wear a respirator when checking the filters.

### To change the filters

1. DISCONNECT THE MACHINE FROM THE POWER SUPPLY.

2. Un-latch the filter retaining clips from the top and bottom of the unit, (Fig.6) and remove the outer filter. Place the filter in a trash bag and shake it gently to remove the bulk of the dust.

**NOTE:** If you choose to use compressed air to further clean the outer filter, do so outdoors in an appropriate environment where people are not in the immediate vicinity.

3. Remove the inner filter, place it inside a trash bag and gently shake the dust from the inside of the filter.

**Optional:** Wash the inner filter with water to remove the remaining dust, then let it air dry completely. DO NOT use compressed air on the inner filter

4. Re-install the inner filter, then re-install the outer filter with the wire mesh facing to the inside. Check that the arrow on the outerfilter is pointing towards the air cleaner. (Fig.8)

5. Re-latch the retaining clips to secure the filters.

**NOTE:** During regular use the filters can be cleaned several times before replacement becomes necessary.

To determine whether the filters need to be replaced, hold them up to the sunlight and visually inspect them. If you cannot see through the filters due to caked dust and grim, replace them before putting the air filter back into operation

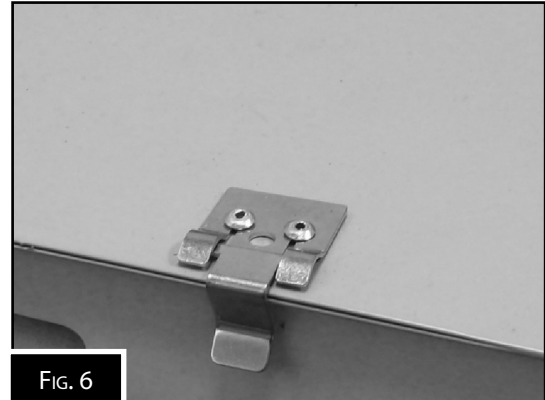

FIG. 6



FIG. 7

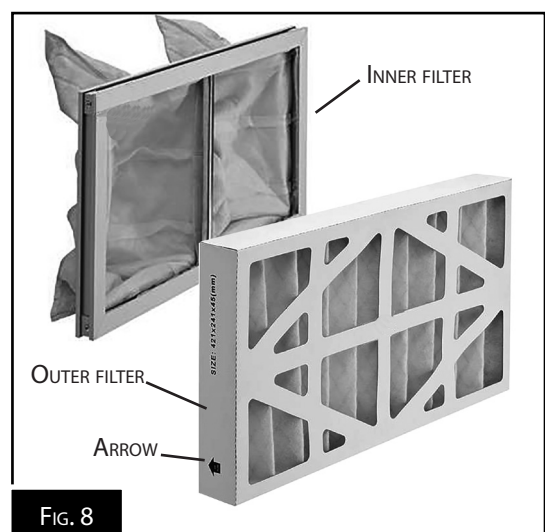

FIG. 8

## OPERATION MANUAL

### 5. MAINTENANCE

Review the troubleshooting and procedures in this section if a problem develops with your machine. If you need replacement parts or additional help with a procedure, contact your distributor

#### 5.1 TROUBLESHOOTING

Symptom	Possible Cause	Possible Solution
Machine does not start or a breaker trips.	<ol style="list-style-type: none"> <li>1. Power supply switched OFF or is at fault.</li> <li>2. Remote control not working or batteries are dead</li> <li>3. Infrared transmission is blocked or remote too far away.</li> <li>4. Wall circuit breaker tripped.</li> <li>5. Control panel fuse blown.</li> <li>6. Infrared receiver at fault.</li> <li>8. Control panel ON SPEED button faulty.</li> <li>9. Motor at fault.</li> </ol>	<ol style="list-style-type: none"> <li>1. Ensure power supply is ON/has correct voltage.</li> <li>2. Replace batteries; point remote control directly at the control panel.</li> <li>3. Make sure the infrared receiver on the control panel is not blocked; try using the remote closer to the filter.</li> <li>4. Ensure circuit breaker is correct or replace.</li> <li>5. Check filters for blown fuse; replace</li> <li>6. Inspect/replace if faulty.</li> <li>8. Replace faulty ON SPEED button.</li> <li>9. Test/repair/replace.</li> </ol>
Machine has vibration or noisy operation.	<ol style="list-style-type: none"> <li>1. Motor or component loose.</li> <li>2. Motor fan rubbing on fan cover.</li> <li>3. Motor bearings at fault.</li> </ol>	<ol style="list-style-type: none"> <li>1. Inspect/replace damaged bolts/nuts, and re-tighten with thread locking fluid.</li> <li>2. Fix/replace fan cover; replace loose/damaged fan.</li> <li>3. Test by rotating shaft; rotational grinding/ loose shaft requires bearing replacement.</li> </ol>
Loud, repetitious noise, or excessive vibration coming from air filter.	<ol style="list-style-type: none"> <li>1. Air filter is not mounted properly and wobbles.</li> <li>2. Impeller fan is damaged, loose, or unbalanced.</li> <li>3. The motor mounting is loose.</li> <li>4. Motor fan housing is dented, causing the motor fan blade to hit the housing while spinning.</li> </ol>	<ol style="list-style-type: none"> <li>1. Stabilize the air filter.</li> <li>2. Unplug air filter, and inspect the impeller for dents, bends, loose fins. Replace impeller if any damage is found.</li> <li>3. Make sure all fasteners on the air filter are tight.</li> <li>4. Replace motor fan housing.</li> </ol>
Air filter does not adequately collect dust; poor performance.	<ol style="list-style-type: none"> <li>1. The filters are dirty.</li> </ol>	<ol style="list-style-type: none"> <li>1. Clean the filters</li> </ol>

## 5.2 FUSE REPLACEMENT

The fuse can be found on the front of the control panel and is designed to blow in the case of a thermal overload. Replace the fuse only with a fast-acting, 1A, 250V fuse

### To replace the machine fuse:

1. DISCONNECT THE MACHINE FROM THE POWER!
2. Unthread the fuse holder cap from the control panel (Fig. 9) and remove it. The fuse will come out with the fuse holder cap.
3. Replace the fuse and fully thread the cap in to secure it.



## 5.3 REMOTE BATTERY CHANGE

The remote control uses two AA batteries. To replace them, slide the battery compartment cover down and off the remote (Fig. 10). Insert the batteries in the proper direction making sure the "+" and "-" are lined up with the markings on the remote and then replace the cover.



## OPERATION MANUAL

### SPARE PARTS SECTION

The following section covers the spare parts diagrams and lists that were current at the time this manual was originally printed. Due to continuous improvements of the machine, changes may be made at any time without notification.

#### HOW TO ORDER SPARE PARTS

1. Have your machines **model number, serial number & date of manufacture** on hand, these can be found on the specification plate mounted on the machine
2. A scanned copy of your parts list/diagram with required spare part/s identified
3. Go to [www.machineryhouse.com.au/contactus](http://www.machineryhouse.com.au/contactus) and fill out the enquiry form attaching a copy of scanned parts list.

#### SPARE PARTS LIST

DRAWING NO.	MANF. PART NO.	DESCRIPTION	QTY	PART TYPE	CODE
1	7NG-04D	HEX NUT	12	M4	GB/T6170-2000
2	7SJAD04-12D	PAN HEAD SCREW	5	M4X12	GB/T818-2000
3	7SJAD06-15D	PAN HEAD SCREW	6	M6X15	GB/T818-2000
4	7040-960017	AIR BOX FRONT COVER	1	A3	95922
5	7040-960004	GRIDE PLATE	1	266X140X1	
6	7104-960001	AIR GUIDE	1	A3	95922
7	7NA-06D	HEX NUT	6	M6	GB/T6170-2000
8	7WF-06D	FLAT WASHER	6	Φ6	GB/T96-1985
9	7WS-06B	LOCK WASHER	6	Φ6	GB/T93-1987
10	7SACD04-12D	SOCKET HEAD CAP SCREW	8	M4X12	GB/T70.2-2000
11	7SJAA04-10D	SELF TAPPING SCREW	10	ST4X10	GB/T845-1985
12	7102-960002	AIR BOX	1	A3	95922
13	7036-960001	HANDLE	1	PA6+GF30	
14	7047-960001	HANDLE BRACKET	1	PA6+GF30	
15	7SJAD05-16D	PAN HEAD SCREW	2	M5X16	GB/T818-2000
16	7WF-05D	FLAT WASHER	3	Φ5	GB/T95-1985
17	7WS-05B	LOCK WASHER	3	Φ5	GB/T93-1987
18	7NA-05D	HEX NUT	6	M5	GB/T6170-2000
19	7SJAD05-12D	PAN HEAD SCREW	1	M5X12	GB/T818-2000
20	7WO-05D	TOOTH LOCK WASHER	2	Φ5	GB/T862.1-1987
21	7010-960005	WIRE-2	1	18AWG	355MM
22	7040-960006	GRIDE PLATE	1	251X428	
23	7163-960003	INNER POCKET FILTER	1	421x241x160	
24	7163-960001	ELECTOSTATIC OUTER FILTER	1	421x241x45	
25	7070-960001	RUBBER FOOT	4		
26	7035-960002	REMOTE CONTROL LABEL	1		
27	7040-960001	REMOTE CONTROL TOP COVER	1		
28	7060-960001	BATTERY	2	AA	
29	7017-960001	SPRING	1		
30	7040-960002	REMOTE CONTROL BOTTOM COVER	1		
31	7040-960003	BATTERY COVER	1		
32	7040-960013	REMOTE CONTROL PCB	1		

## OPERATION MANUAL

### SPARE PARTS LIST

DRAWING NO.	MANF. PART NO.	DESCRIPTION	QTY	PART TYPE	CODE
33	7007-960005	POWER CORD	1	1.8M	0.75MMX3
34	7112-960003	STRAIN RELIEF	1	6P-4	
35	7SJAD05-20D	PAN HEAD SCREW	1	M5X20	GB/T818-2000
36	7031-960004	FUSE HOLDER	1		
37	7031-960004	FUSE HOLDER CAP	1		
38	7111-960002	FUSE	1	UL250V 1A	
39	7035-960032	CONTROL PANEL LABEL	1		
40	7SEAB03-18D	FLAT HEAD TAP SCREW	2	ST3X18	
41	7040-960007	SWITCH BOX COVER	1		
42	7SJAB04-14D	SELF TAPPING SCREW	2	ST4X14	
43	7070-960002	INSULATION WASHER	2	Φ3 #4170	
44	7040-960014	CIRCUIT BOARD	1		
45	7031-960001	SWITCH BOX	1		
46	7010-960004	WIRE-1	1	18AWG	170MM
47	7043-960001	FAN WHEEL	1		
48	7097-960001	FAN HOUSING COVER-L	1		
49	7097-960001	FAN HOUSING COVER-M	1		
50	7SJAD04-10D	PAN HEAD SCREW	10	M4X10	GB/T818-2000
51	7064-960001	RUBBER SPACER	4		
52	7143-960001	LARGE WASHER	4	Φ5	GB/T96-1985
53	7NG-05D	NYLON INSERT LOCK NUT	4	M5	
54	7SFDD05-25D	HEX CAP SCREW	4	M5X25	GB/T5783-2000
55	7097-960001	FAN HOUSING COVER-R	1		
56	7110-960003	MOTOR	1		
57	7008-960002	CAPACITOR	1		3mF±5% 400V
58	7WO-04D	TOOTH LOCK WASHER	1	Φ4	GB/T95-1985
59	7031-960002	CAPACITOR COVER	1		
60	7038-960001	YELLOW TUBE	6		
61	7049-960001	EYE BOLT	4		
62	7ND-06D	FLANGE NUT	4	M6	GB/T6177.1-2000
63	7049-960003	HOOK CHAIN	4		
64	7049-960002	HOOK SCREW	4		
65	7SQAD06-12D	PAN HEAD SCREW	4	M6X12	GB/T818-2000



# OPERATION MANUAL

## SPARE PARTS DIAGRAM

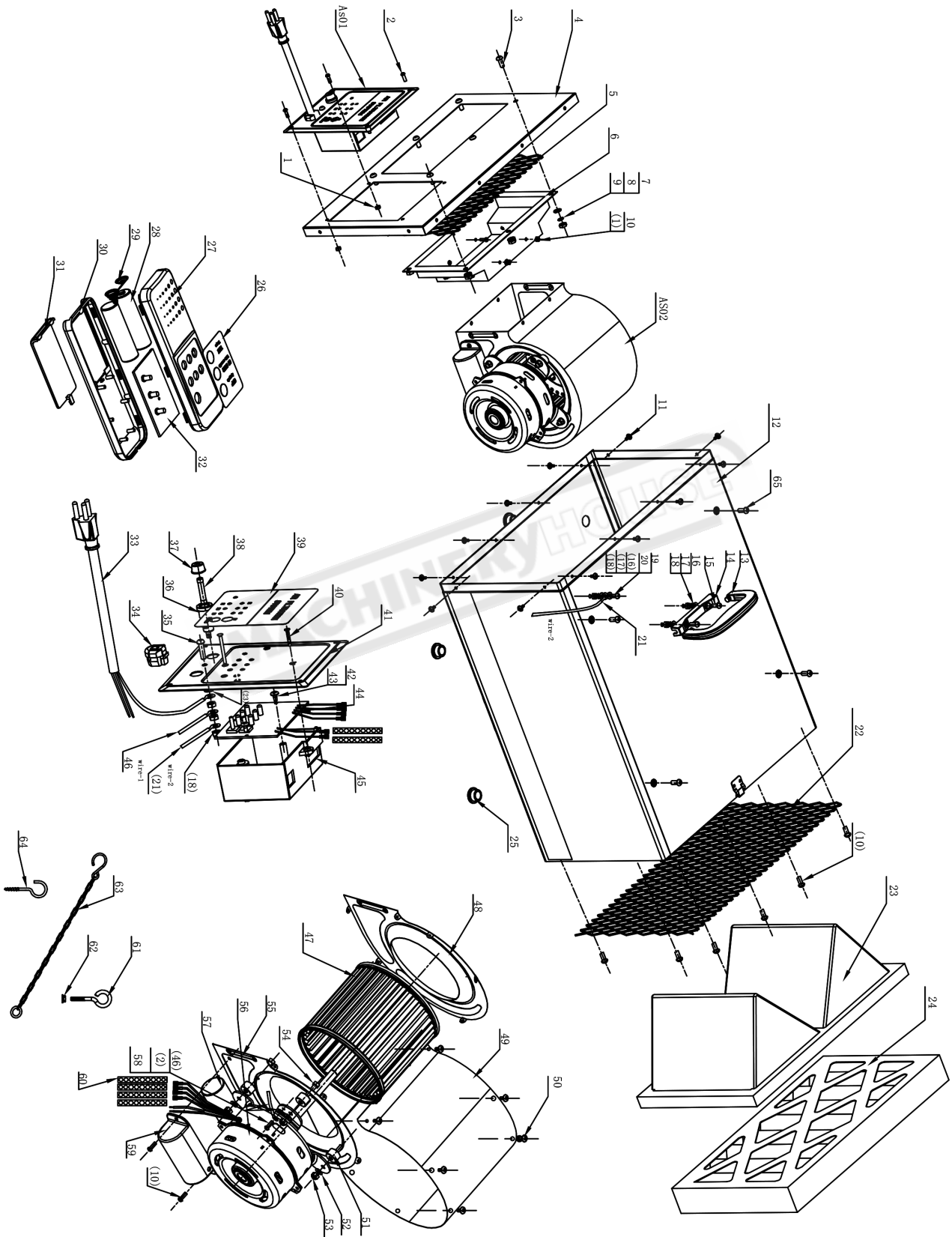





# WARNING

## General Machinery Safety Instructions

---

Machinery House  
requires you to read this entire Manual before using this machine.

- 1. Read the entire Manual before starting machinery.** Machinery may cause serious injury if not correctly used.
- 2. Always use correct hearing protection when operating machinery.** Machinery noise may cause permanent hearing damage.
- 3. Machinery must never be used when tired, or under the influence of drugs or alcohol.** When running machinery you must be alert at all times.
- 4. Wear correct Clothing.** At all times remove all loose clothing, necklaces, rings, jewelry, etc. Long hair must be contained in a hair net. Non-slip protective footwear must be worn.
- 5. Always wear correct respirators around fumes or dust when operating machinery.** Machinery fumes & dust can cause serious respiratory illness. Dust extractors must be used where applicable.
- 6. Always wear correct safety glasses.** When machining you must use the correct eye protection to prevent injuring your eyes.
- 7. Keep work clean and make sure you have good lighting.** Cluttered and dark shadows may cause accidents.
- 8. Personnel must be properly trained or well supervised when operating machinery.** Make sure you have clear and safe understanding of the machine you are operating.
- 9. Keep children and visitors away.** Make sure children and visitors are at a safe distance for you work area.
- 10. Keep your workshop childproof.** Use padlocks, Turn off master power switches and remove start switch keys.
- 11. Never leave machine unattended.** Turn power off and wait till machine has come to a complete stop before leaving the machine unattended.
- 12. Make a safe working environment.** Do not use machine in a damp, wet area, or where flammable or noxious fumes may exist.
- 13. Disconnect main power before service machine.** Make sure power switch is in the off position before re-connecting.
- 14. Use correct amperage extension cords.** Undersized extension cords overheat and lose power. Replace extension cords if they become damaged.
- 15. Keep machine well maintained.** Keep blades sharp and clean for best and safest performance. Follow instructions when lubricating and changing accessories.
- 16. Keep machine well guarded.** Make sure guards on machine are in place and are all working correctly.
- 17. Do not overreach.** Keep proper footing and balance at all times.
- 18. Secure workpiece.** Use clamps or a vice to hold the workpiece where practical. Keeping the workpiece secure will free up your hand to operate the machine and will protect hand from injury.
- 19. Check machine over before operating.** Check machine for damaged parts, loose bolts, Keys and wrenches left on machine and any other conditions that may effect the machines operation. Repair and replace damaged parts.
- 20. Use recommended accessories.** Refer to instruction manual or ask correct service officer when using accessories. The use of improper accessories may cause the risk of injury.
- 21. Do not force machinery.** Work at the speed and capacity at which the machine or accessory was designed.
- 22. Use correct lifting practice.** Always use the correct lifting methods when using machinery. Incorrect lifting methods can cause serious injury.
- 23. Lock mobile bases.** Make sure any mobile bases are locked before using machine.
- 24. Allergic reactions.** Certain metal shavings and cutting fluids may cause an allergic reaction in people and animals, especially when cutting as the fumes can be inhaled. Make sure you know what type of metal and cutting fluid you will be exposed to and how to avoid contamination.
- 25. Call for help.** If at any time you experience difficulties, stop the machine and call you nearest branch service department for help.

# WARNING

## Air Filtration Unit Safety Instructions

---

Machinery House  
requires you to read this entire Manual before using this machine.

- 1. Maintenance.** Make sure the Air Filtration Unit is turned off and disconnect from the main power supply and make sure all moving parts have come to a complete stop before any inspection, adjustment or maintenance is carried out.
- 2. Air Filtration Unit Condition.** Air Filtration Unit must be maintained for a proper working condition. Never operate a Air Filtration Unit that has damaged or worn parts. Scheduled routine maintenance should be performed on a scheduled basis.
- 3. Operating safety.** Do not place hands or tools near the open inlets during operation for any reason.
- 4. To be used for Wood Dust Filtration.** Do not use this machine to filter or collect liquids (especially flammables), metal shavings, lead paint, or asbestos. Do not use this machine to dissipate smoke, fumes, or when spray painting. This unit is designed to remove very fine wood particles from the air. It is not a dust collector.
- 5. Understand the machines controls.** Make sure you understand the use and operation of all controls.
- 6. Work area hazards.** Only operate this Air Filtration unit in dry environments.
- 7. Unplug machine before removing filter.** Keep the filters serviced, Never replace the filters while the machine is operating.
- 8. Filter & guards.** All Filters and guards must be used at all times. Filters must be serviced and replaced when damaged.
- 9. Emptying bags hazard.** Always wear a respirator and safety glasses when emptying dust into approved containers and dispose of properly.
- 10. Wood dust may cause allergic reactions.** Make sure you know what type of dust you are exposed to as it may cause you an allergic reaction. Always wear an approved respirator. Keep your Air Filtration unit filters clean for optimum performance to minimize respiratory exposure to dust.
- 11. Do not use this machine to protect against Lead or asbestos fibers.** These materials must be collected with special equipment because of the high hazard to human health. Do not attempt to collect these materials with this machine.
- 12. Call for help.** If at any time you experience difficulties, stop the machine and call you nearest branch service department for help.

# PLANT SAFETY PROGRAM

## **NEW MACHINERY HAZARD IDENTIFICATION, ASSESSMENT & CONTROL**

### **Air Filtration Unit**

Developed in Co-operation Between A.W.I.S.A and Australia Chamber of Manufactures  
This program is based upon the Safe Work Australia, Code of Practice - Managing Risks of Plant in the Workplace ( WHSA 2011 No10 )

Item No.	Hazard Identification	Hazard Assessment	Risk Control Strategies <small>(Recommended for Purchase / Buyer / User)</small>
B	CRUSHING	LOW	Ensure air filter is on level solid ground and in a safe place to avoid tipping.
C	CUTTING, STABBING, PUNCTURING	MEDIUM	Isolate power to machine prior to any checks or maintenance being carried out. Do not adjust or clean dust collector until fully stopped. Ensure hose remains fitted to prevent access to fan blade. Keep body parts away from moving parts.
H	ELECTRICAL	MEDIUM	All electrical enclosures should only be opened with a tool that is not to be kept with the machine. Machine should be installed & checked by a Licensed Electrician.
O	OTHER HAZARDS, NOISE.	LOW	Wear hearing protection as required.
Plant Safety Program to be read in conjunction with manufactures instructions			



[www.machineryhouse.com.au](http://www.machineryhouse.com.au)



[www.machineryhouse.co.nz](http://www.machineryhouse.co.nz)

Authorised and signed by:

Safety officer:

Manager:

Revised Date: 12th March 2012